

MSXB 029:
Analog Backplane Interface Board

Analog Accelerator Series
Microstar Laboratories, Inc.

Version 1.2

This manual contains proprietary information which is protected by copyright. All rights are reserved. No part of this manual may be photocopied, reproduced, or translated to another language without prior written consent of Microstar Laboratories, Inc.

Copyright © 1996-2000

Microstar Laboratories, Inc.
2265 116 Avenue N.E.
Bellevue, WA 98004
Tel: (425) 453-2345
Fax: (425) 453-3199

Microstar Laboratories, Data Acquisition Processor, DAPL, DAPL 2000, DAP, DAP 800, DAP 1200a, DAP 2400a, DAP 1216a, DAP 2416a, DAP 3000a, DAP 3200a, DAP 3400a, DAPtools, Analog Accelerator, DAPview, and Channel List Clocking are trademarks of Microstar Laboratories, Inc. Other brand and product names are trademarks or registered trademarks of their respective holders.

Microstar Laboratories requires express written approval from its President if any Microstar Laboratories products are to be used in or with systems, devices, or applications in which failure can be expected to endanger human life.

Part Number MSAMXB029-0900-01

Contents

Contents	3
MSXB 029 Analog Backplane Interface Board	5
Hardware Configuration	6
Daisy-Chaining Analog Backplanes	6
Power Consumption.....	8
Power Options	8
Figures:	
Figure 1. MSXB 029: Analog Backplane Interface Board.....	6
Figure 2. Example of a Daisy-Chained Analog Backplane System	7
Figure 3. External Power Connector	8

MSXB 029 Analog Backplane Interface Board

The Microstar Laboratories Analog Backplane Interface Board, part number MSXB 029, interfaces the Analog Backplane with a Data Acquisition Processor. The Analog Backplane Interface Board must be installed in the Analog Backplane to connect the backplane to a Data Acquisition Processor.

An optional stand-alone model of the Analog Backplane Interface Board provides analog power to analog external boards for use outside of the Analog Backplane.

Hardware Configuration

The Analog Backplane Interface Board can be installed into any free slot of the Analog Backplane. When installing the Analog Backplane Interface Board, push the board firmly into the slot and make sure the board is securely connected to the Analog Backplane. Secure the Analog Backplane Interface Board front panel to the Industrial Enclosure with the two screws provided.

Warning: Never install a board into the Analog Backplane or remove a board from the Analog Backplane while the Analog Backplane is powered.

The Analog Backplane Interface Board connects to a Data Acquisition Processor through connector J2 by means of the MSCBL 040 shielded cable, or the MSCBL 041 ribbon cable.

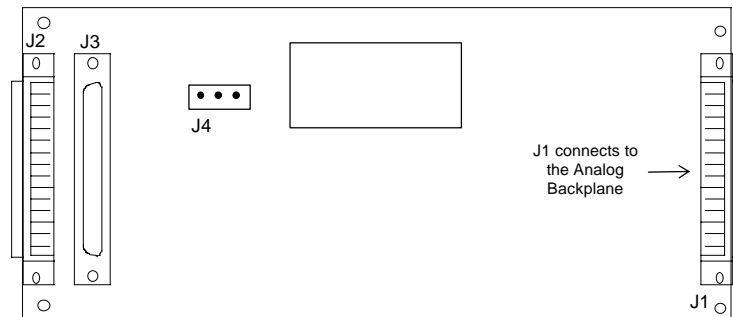

Figure 1. MSXB 029: Analog Backplane Interface Board

Daisy-Chaining Analog Backplanes

Connector J3 provides the option of connecting another Analog Backplane in a daisy-chain by means of the MSCBL 060 panel-mount cable.

The MSCBL 060 cable would be installed into the adjacent slot on the right side of the Analog Backplane Interface Board. Another analog backplane would connect to the MSCBL 060 cable. On the optional stand-alone model of the Analog Backplane Interface Board, connector J1 is used to connect to external boards by means of the MSCBL 040 shielded cable or the MSCBL 041 ribbon cable. This model cannot be installed in the Analog Backplane. Connector J2 or J3 is connected to the Data Acquisition Processor, similar to the standard models.

The following diagram shows the daisy-chain configuration:

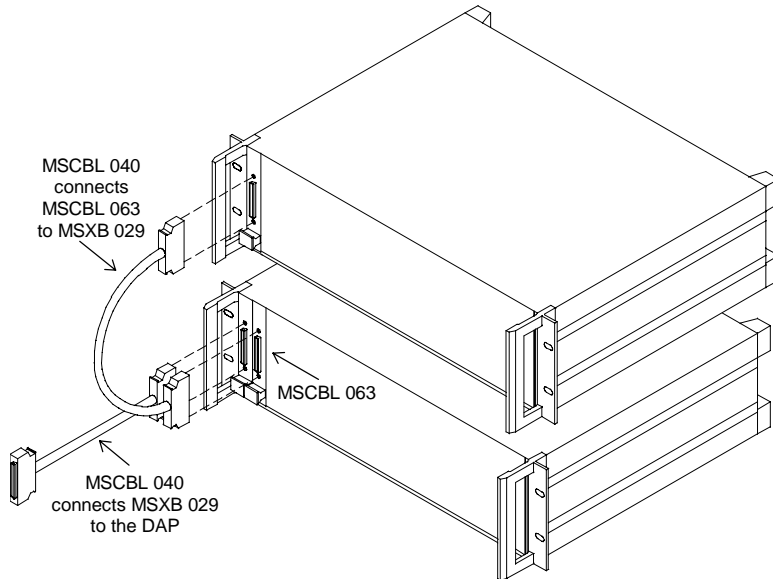

Figure 2. Example of a Daisy-Chained Analog Backplane System

The number of daisy-chained backplanes is limited by cable length. Microstar Laboratories suggests that the combined cable length from the DAP to the last backplane be no longer than 72".

Power Consumption

The Analog Backplane provides power to each slot by means of three voltage supplies: +5V, +18V, and -18V. If the total power consumption of all external boards installed in the Analog Backplane does not exceed the available power supply of the Data Acquisition Processor, the Analog Backplane can draw power from the Data Acquisition Processor. If the total power consumption exceeds this limit, external power must be supplied to the Analog Backplane. Please refer to the hardware documentation of the Analog Backplane and external boards for more information on power consumption.

Power Options

The Analog Backplane Interface Board has external power models to meet the power consumption requirements of different systems:

- If the power consumption of the backplane system does not exceed the DAP's power availability, the MSXB 029-03-E2A model or the stand-alone MSXB 029-03-A2Z of the Analog Backplane Interface Board is used. These models use power from the DAP's +5V supply to generate the +18V and -18V supplies and provide them for the Analog Backplane or the analog system. These models also distribute the DAP's +5V supply directly to the Analog Backplane or to the analog system.
- If the system requires external power, the MSXB 029-04-E2A model or the stand-alone MSXB 029-04-A2Z model of the Analog Backplane Interface Board must be used. In these models, the DAP's +5V supply is separated from the backplane's +5V supply. For a backplane system, an external +5V supply must be connected directly to the Analog Backplane. The MSXB 029-04-E2A uses power from the backplane's external +5V supply to generate the +18V and -18V supplies and provides them for the backplane. For the stand-alone MSXB 029-04-A2Z model, an external +5V supply must be connected to J4 of the Analog Backplane Interface Board. Connector J4 is a male Molex connector part number 26-60-4030 and mates with the Molex connector part number 09-50-3031. The mating connector is included with the Microstar Laboratories cable kit MSCBL 027-01K.

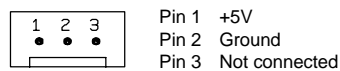

Figure 3. External Power Connector

All models of the Analog Backplane Interface Board convert power from +5V to +18V and -18V with an efficiency of 80%. This efficiency must be considered in calculating the power consumption of a backplane system. Please refer to the hardware documentation of the Analog Backplane for information on calculating power consumption.